

# Welcome to the world of surface technology



**Hartverchromung**  
*hard chromium-plating*  
*chromage dur*

**Mehrschicht-Hartverchromung**  
*multilayer hard chromium-plating*  
*chromage dur multicouches*

**strukturierte Oberflächen**  
*structured surfaces*  
*surfaces structurées*

**Sonderbeschichtung**  
*special coating*  
*revêtement spécial*

**spiegelhochglanz Polieren**  
*mirror polishing*  
*polissage effet miroir*

**Rundschleifen**  
*cylindrical grinding*  
*retification cylindrique*

**Engineering**  
*roller and cylinder engineering*  
*engineering de rouleaux et cylindres*



**Parzer Gruppe**  
**Parzer Group**

# Die Parzer Gruppe. Zeitlos und beständig.

Die Parzer Gruppe (280 Mitarbeiter) ist ein Verbund aus Partnerunternehmen in Deutschland, Österreich und der Schweiz. Die Technologieschwerpunkte umfassen:

Technische Hartverchromung, Chemisch Nickel, Präzisions-Rundschleifen und Polieren, Wärmebehandlungen bis 300° und komplexe Engineering-Lösungen





**Anke GmbH & Co. KG**  
 Am Stadthafen 42  
 D-45356 Essen

T +49 (0) 201 / 89 55-0  
 F +49 (0) 201 / 89 55-111  
 info@anke-essen.de  
 www.anke-essen.de



**Strötzel Oberflächentechnik GmbH & Co. KG**  
 Hafestraße 11+13  
 D-31137 Hildesheim

T +49 (0) 5121 / 78 16-0  
 F +49 (0) 5121 / 51 11 45  
 info@stroetzel.de  
 www.stroetzel.de

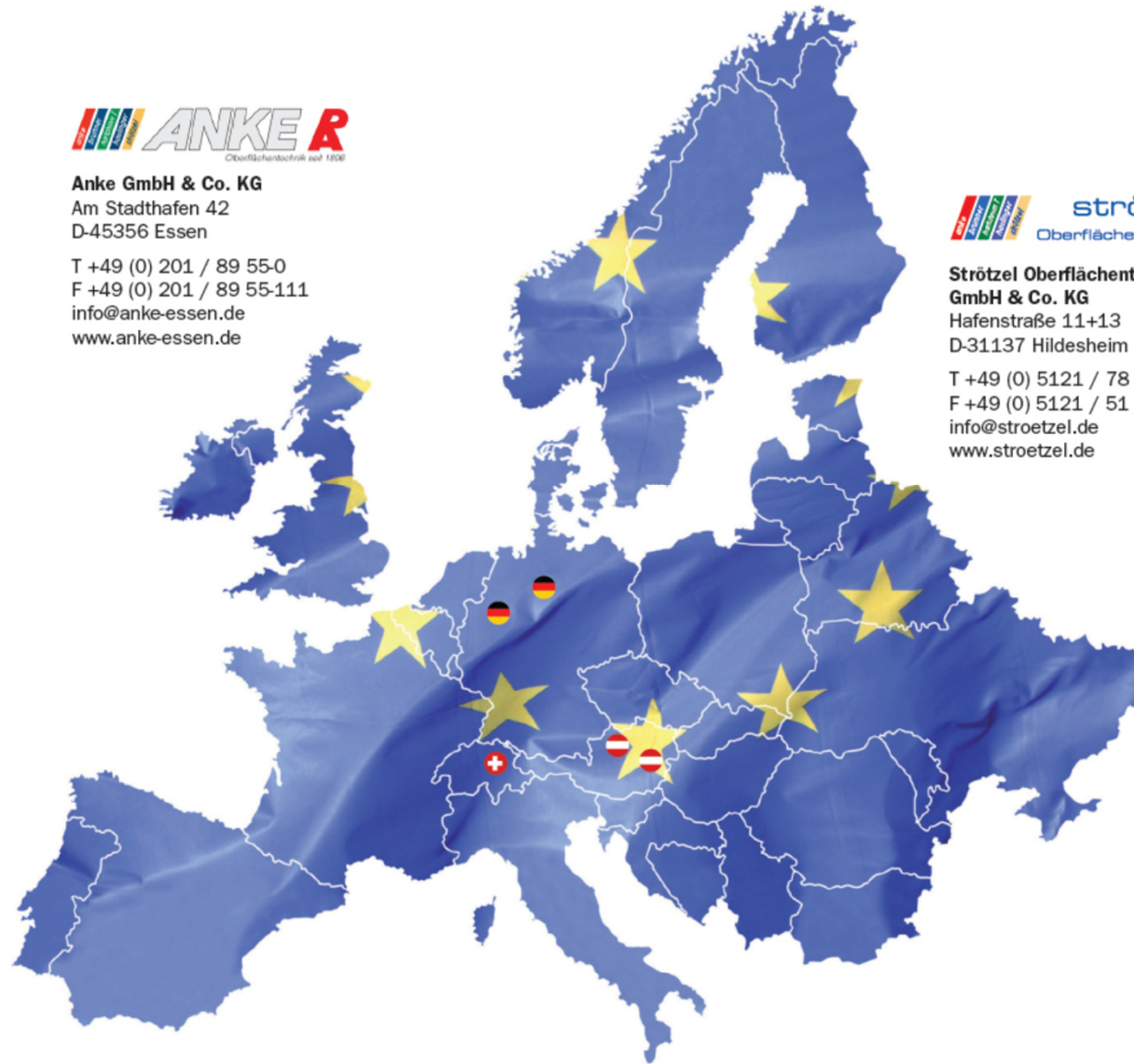

**Hartchromwerk Brunner AG**  
 Martinsbruggstrasse 94  
 CH-9016 St. Gallen

T +41 (0) 71 / 282 40 60  
 F +41 (0) 71 / 282 40 70  
 welcome@hcwb.com  
 www.hcwb.com



**Hartchrom Haslinger Oberflächentechnik Ges.m.b.H.**  
 Pummererstraße 21-25  
 A-4020 Linz

T +43 (0) 732 / 77 83 65  
 F +43 (0) 732 / 77 31 67-21  
 office@hartchrom.at  
 www.hartchrom.at



**Hartchrom T G.m.b.H.**  
 Dr. Bolza-Schünemann Str. 18  
 A-2630 Ternitz

T +43 (0) 2630 / 22004  
 office@hartchrom-t.at



**Parzer Gruppe**  
**Parzer Group**

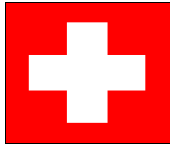

**Hartchromwerk Brunner AG**

CH-9016 St. Gallen

[www.hcwb.com](http://www.hcwb.com)

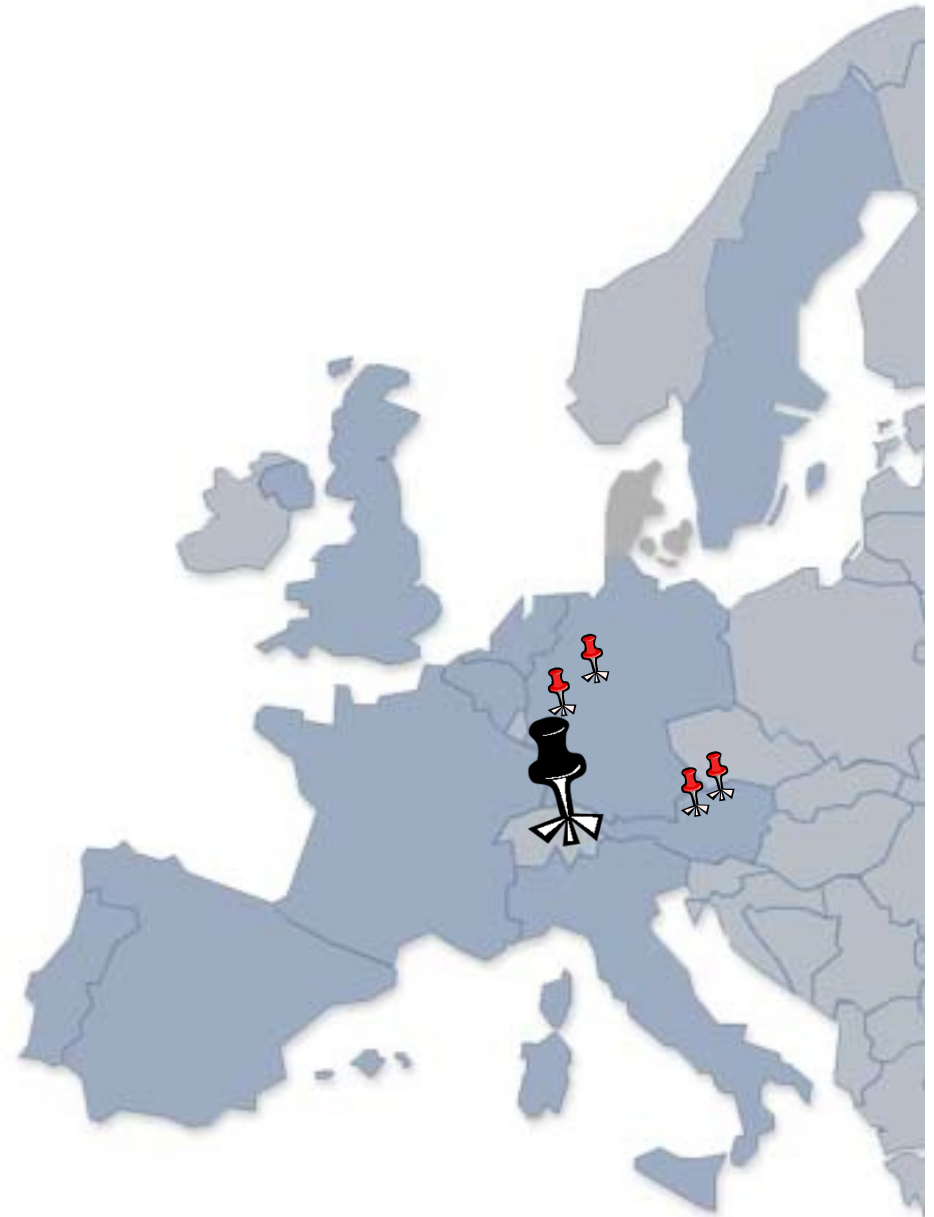

Parzer Gruppe

Parzer Group

## Werk 1



## Werk 2



## Kompetenzen

<b>Techn. Hartverchromung</b>	<b>Durchmesser</b>	<b>3'200 mm</b>
	<b>Länge</b>	<b>12'000 mm</b>
	<b>Gewicht</b>	<b>25 t</b>
<b>Rundschleifen / Polieren</b>	<b>Durchmesser</b>	<b>3'200 mm</b>
	<b>Länge</b>	<b>12'000 mm</b>
	<b>Gewicht</b>	<b>25 t</b>
<b>Dehydrieren</b>	<b>Breite/Durchmesser</b>	<b>2'300 mm</b>
	<b>Länge</b>	<b>8'000 mm</b>
	<b>Gewicht</b>	<b>15 t</b>
<b>weitere Dienstleistungen</b>		
<b>komplette Fertigungen</b>		
<b>technische Auslegung von Walzen</b>		
<b>Sonderbeschichtungen (z.B. Antihaft)</b>		
<b>Schulungen</b>		

# Beschichtungen

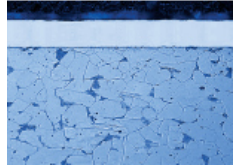

## Hartverchromung Durit®-Spezialverfahren

Funktionsbeschichtungen, Oberflächengüte von Spiegelhochglanz  
Rz 0.05 µm bis definierte Strukturschichten Rz 50 µm

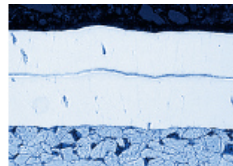

## Mehrschicht-Hartverchromung M-Durit®-Spezialverfahren

Von 2 bis 10 Schichten für erhöhten Korrosionsschutz und hohe  
Abrasionsbeständigkeit

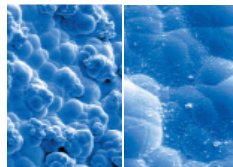

## Mattverchromung Satin®-Spezialverfahren

Elektrolytisch mattierte und mechanisch strukturierte Oberflächen  
Angepasste Topografie der Oberflächen für die Verarbeitung von Textil,  
Nonwoven, Papier, Folien, Prepreg (CFK) sowie Kunststoffe u.a. Materialien

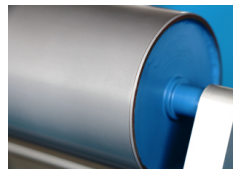

## Durit®-Teflonchrom

Antihaft, durch zusätzlichen chemischen Behandlung der Chromschicht  
können PTFE-Gleitstoffe in die Oberfläche eingelagert werden



## Durit®-Black-Sky 50

Hohe Verschleissfestigkeit und Antihafteffekt durch spezielle  
Oberflächenbehandlung und auftragen von PTFE



## Durit®-Nano Aqua

Mittels Sol-Gel-Verfahren werden Nanopartikel auf die vorhandene  
Chromschicht appliziert. Hohe Verschleissfestigkeit, Antihafteffekt und  
einfache Reinigung „easy to clean“

# Technische Hartverchromung

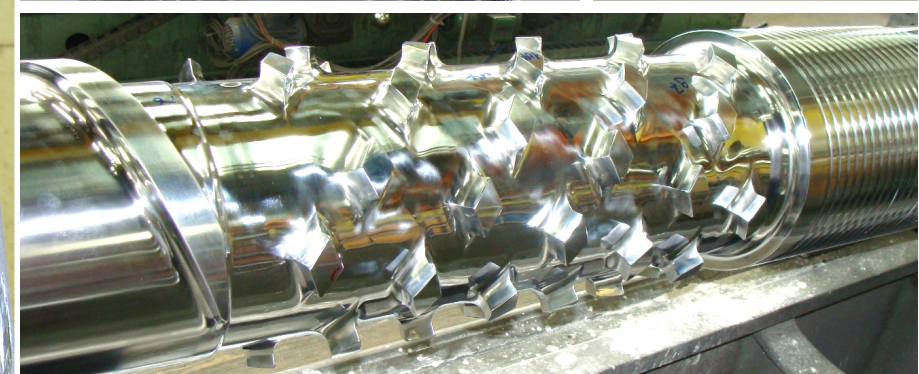
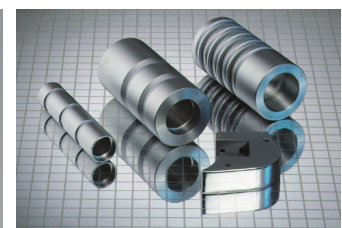
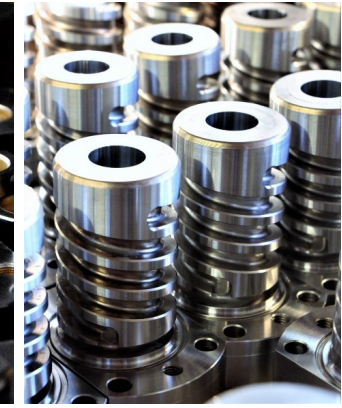



# Neues Chrombad Glasfaserbau >Dm 3'200mm

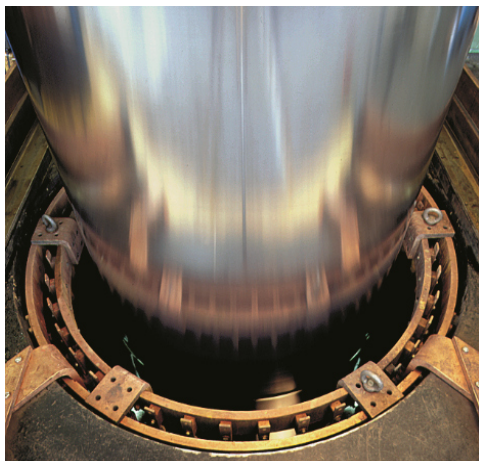

## Spezialbeschichtungen

mechanisch strukturiert oder in Teflon/Chrom Kombination

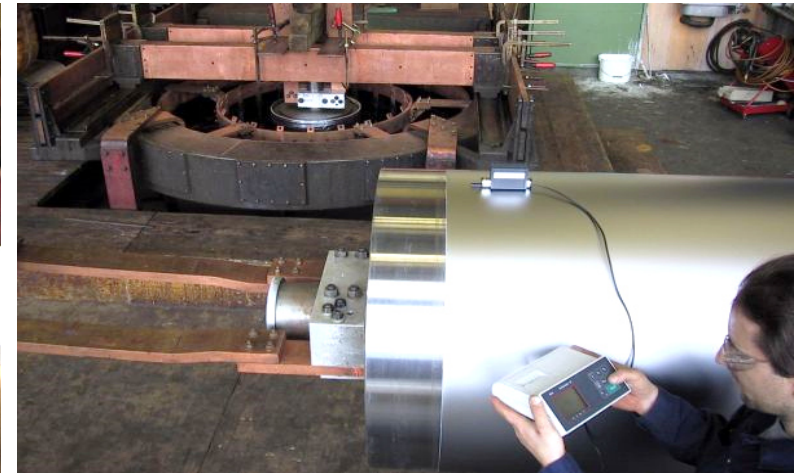

Beschichten



Drucken/Lackieren



Trocknen



Laminieren/Kaschieren



Prägen/Glätten



Wickeln



Konfektionieren



Antriebstechnik



## Hartverchromen von Endlosbänder

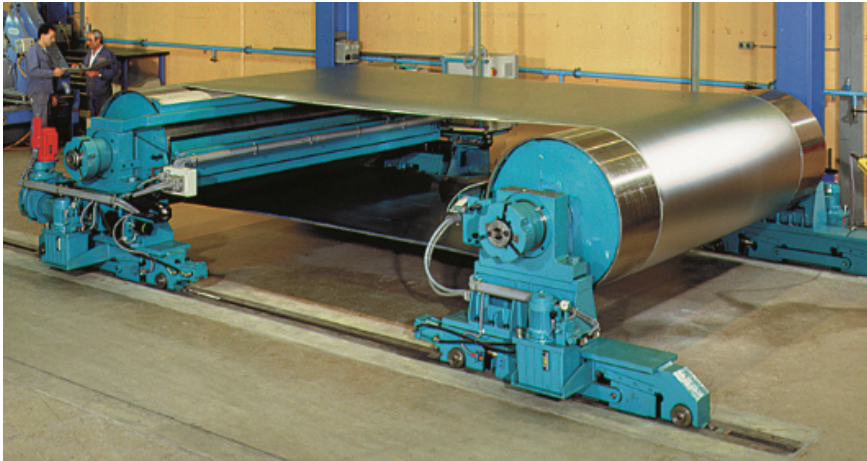

# Pressplatten (glatt oder strukturiert)

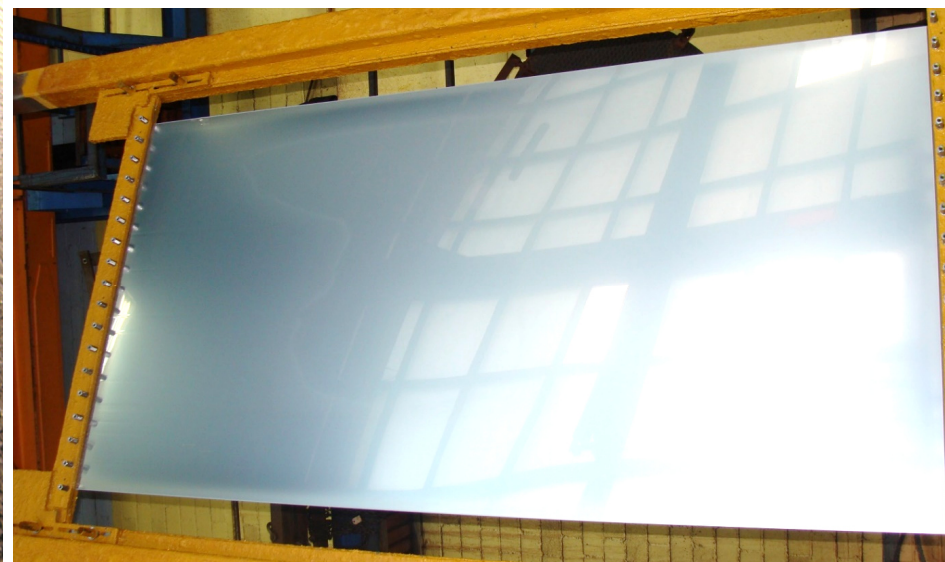

## Kolbenoberteile für Dieselmotoren, Antriebe

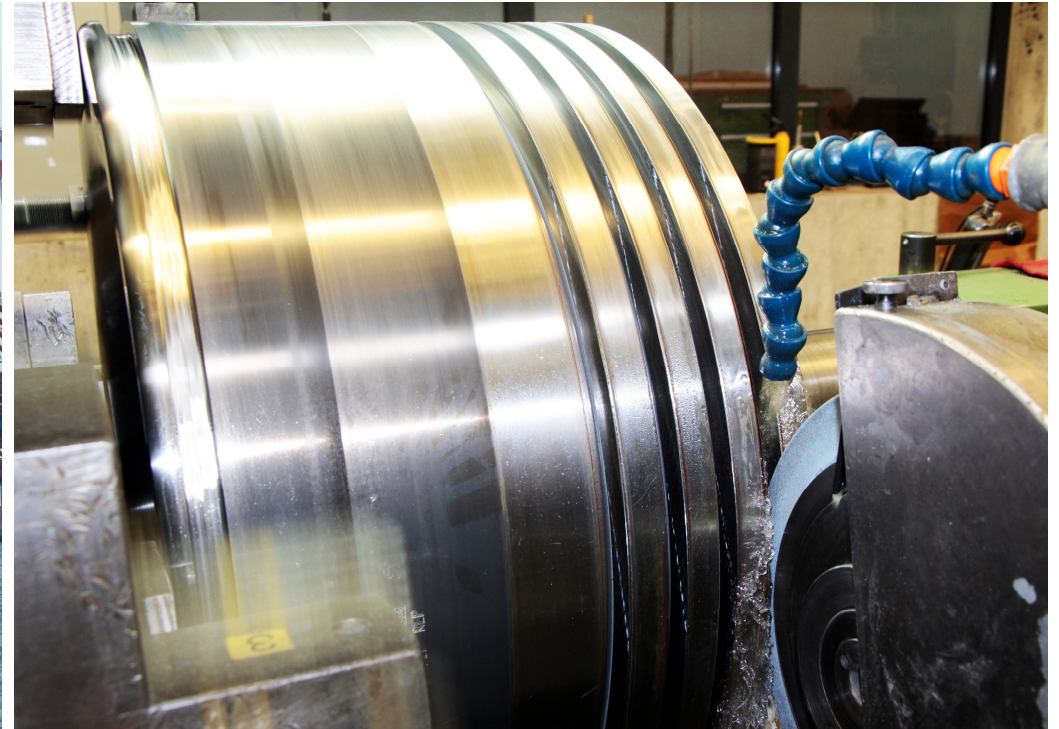

## Extruderschnecken

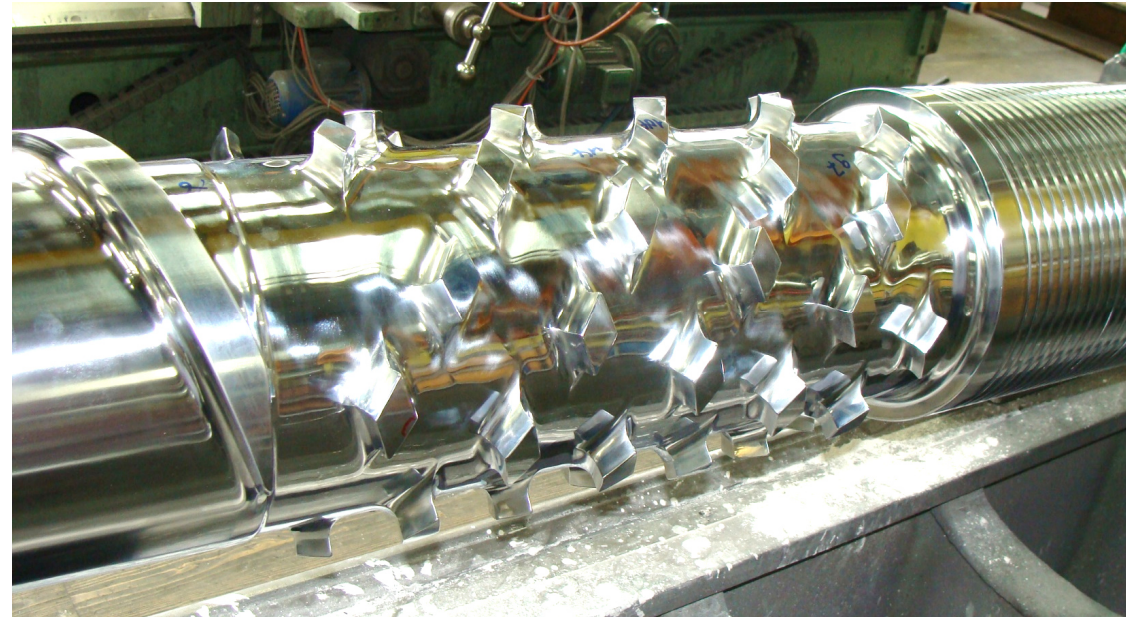
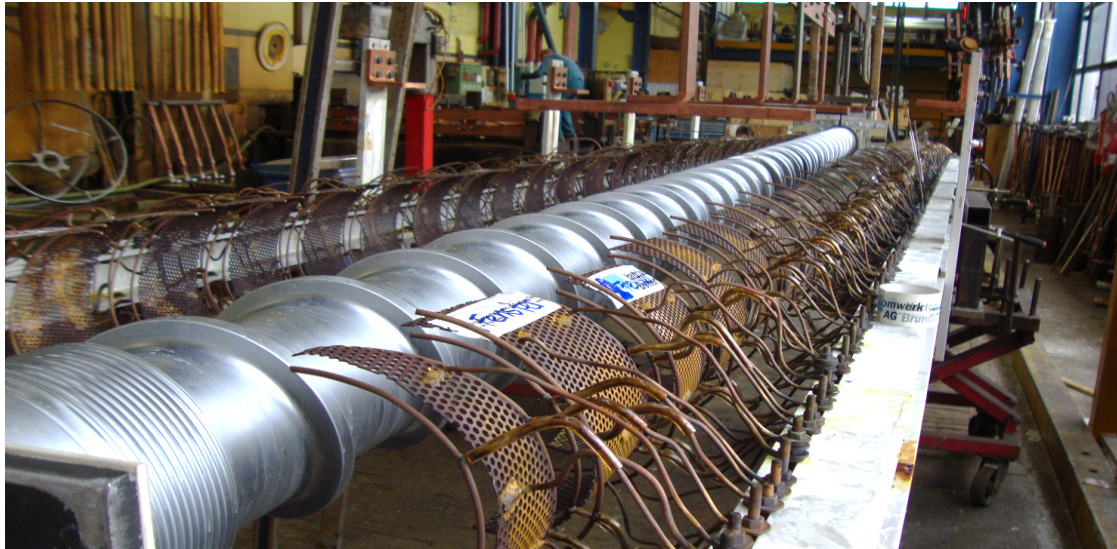

## Kunststoffindustrie

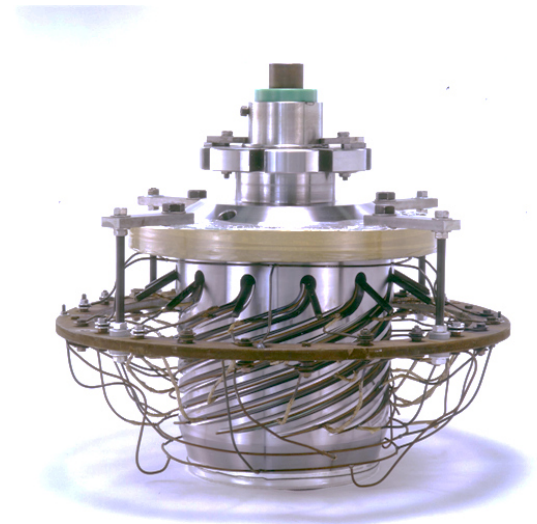
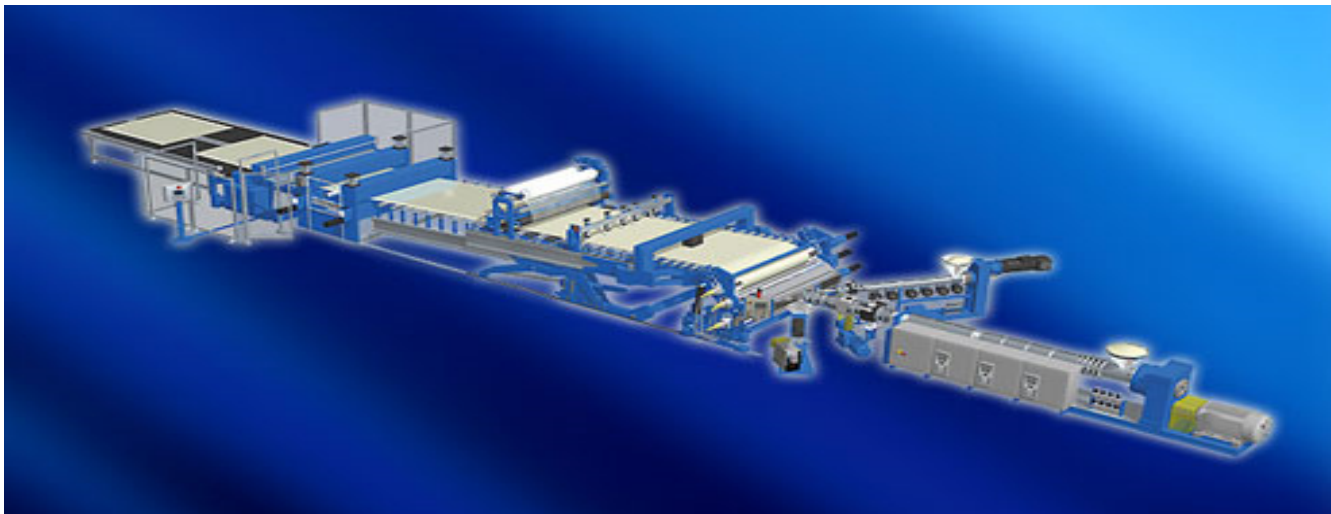



# Ringkolben für Ventilsteuerung Wasserkraftwerke



## Gas- und Ölpipeline



## Stiften und Reparieren eines Zylinders für die Papierindustrie



### Druckprüfung – Innenreinigung



## Hartverchromung - Innenbereiche

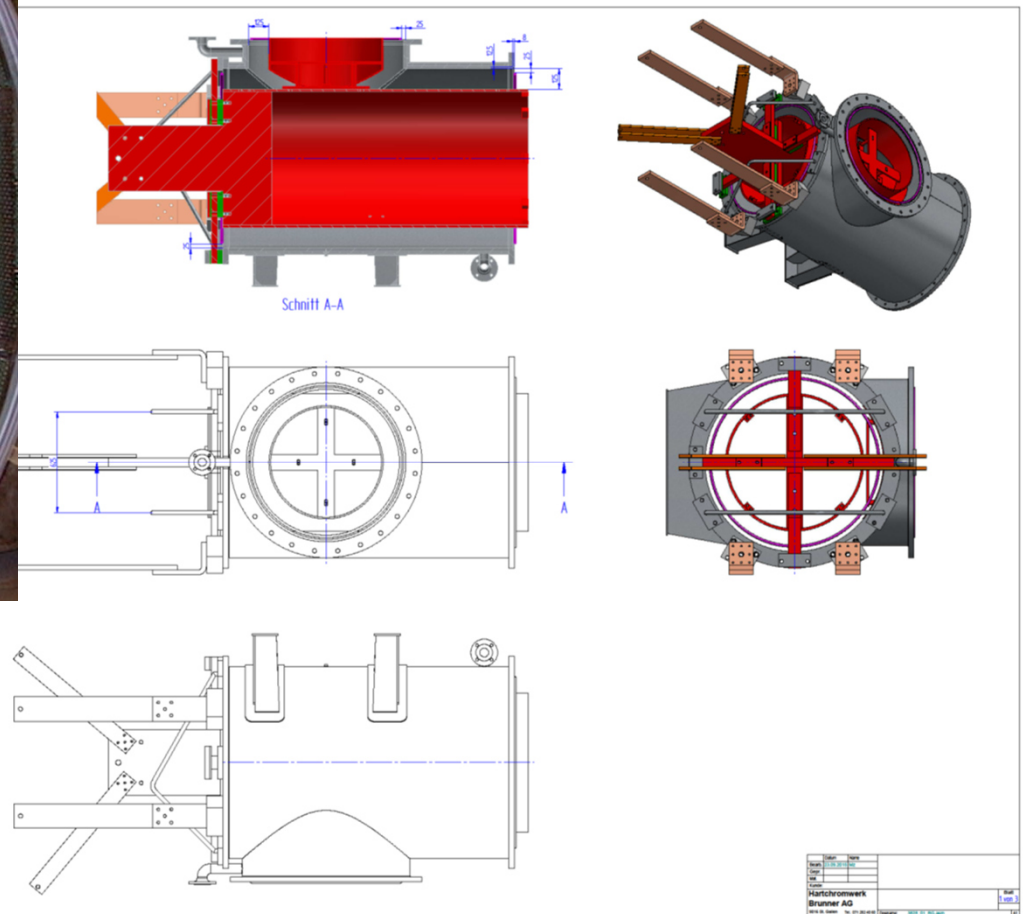

## Rundschleifen

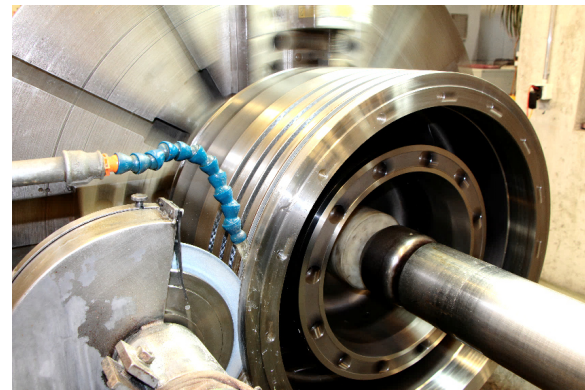
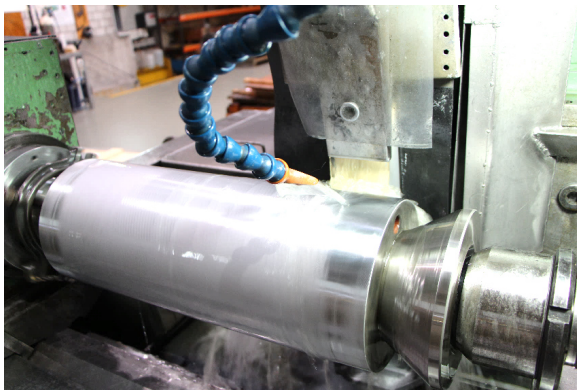
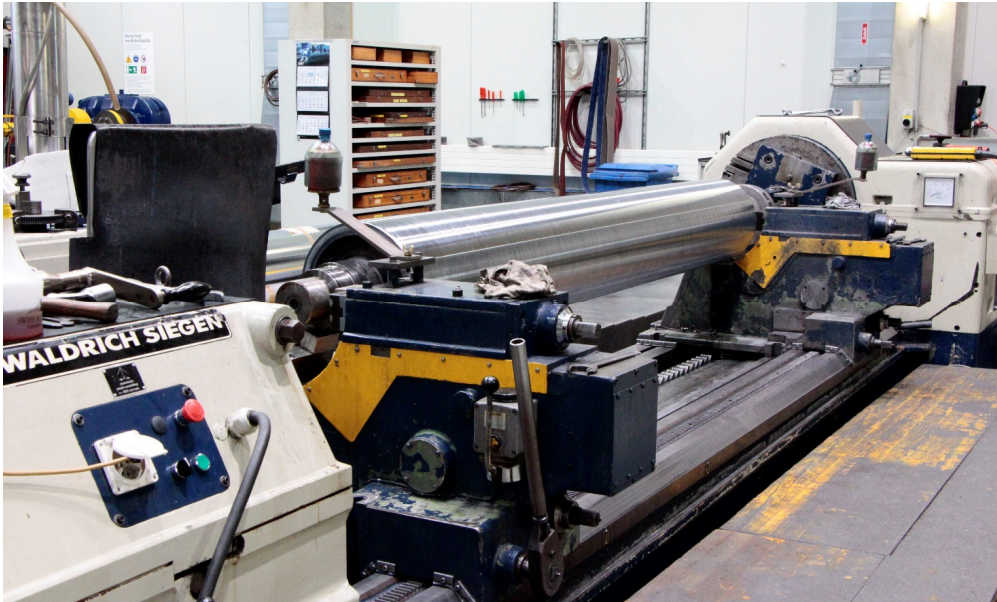

# Spiegelhochglanz Polieren



# Hartchromwerk Brunner AG



Parzer Gruppe  
Parzer Group

# Dehydrieren



# Unsere Basis

- **Motivierte und gut ausgebildete Mitarbeiter**
- **Spezialitäten bzw. Alleinstellungsmerkmale**
- **Qualität und Dienstleistung am Kundenbedürfnis**





Parzer Gruppe  
Parzer Group

# Messepräsenz Parzer Gruppe

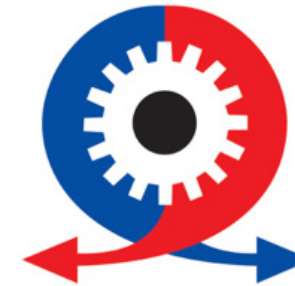

## techtex

SWISS TECH <sup>16</sup>

15.–18.11.2016 | Messe Basel  
Internationale Fachmesse für Werkstoffe,  
Komponenten und Systembau



Parzer Gruppe  
Parzer Group

## Messestand Parzer Gruppe



# Kontakt

Hartchromwerk Brunner AG  
Martinsbruggstrasse 94

Tel + 41 (0)71 282 40 60

Fax + 41 (0)71 282 40 70

[welcome@hcwb.com](mailto:welcome@hcwb.com)

[www.hcwb.com](http://www.hcwb.com)

## Geschäftsleitung

**Bernhard Meier**  
**Kai Bockenheimer**

Vertrieb / Marketing / Projekte / Entwicklung  
Produktion / Technik / Betrieb

**Patrick Gasser**  
**Peter Müller**

Verkauf back office  
Verkauf back office

**Paulo Bravo**

Export / Marketing

**Wir freuen uns auf gemeinsame Projekte mit Ihnen**

